

# VikingLink

nationalgrid

---

## UK Onshore Scheme

### Soil Handling and Storage Protocol

VKL-08-39-G500-026

August 2017



# Contents

- 1 INTRODUCTION ..... 1
  - 1.1 Introduction ..... 1
  - 1.2 Roles and Responsibilities..... 1
  - 1.3 Limitations of use of the SHSP ..... 3
  - 1.4 Review and updated of the SHSP ..... 3
  - 1.5 Soil Resource ..... 4
- 2 GOOD PRACTICE MITIGATION..... 5
  - 2.1 General principles of soil handling ..... 5
  - 2.2 Stop conditions..... 6
  - 2.3 Preparation..... 9
  - 2.4 Soil stripping..... 10
  - 2.5 Creation of soil stockpiles ..... 12
  - 2.6 Access along cable trenches ..... 14
  - 2.7 Stockpile Maintenance..... 15
  - 2.8 Stockpile Records ..... 15
  - 2.9 Drainage ..... 15
  - 2.10 Restoration..... 15
  - 2.11 General methods to be used during restoration..... 16
  - 2.12 Achieving the restoration standard..... 18
  - 2.13 Aftercare ..... 19
- 3 BIOSECURITY ..... 20
  - 3.1 Biosecurity ..... 20
- 4 BESPOKE MITIGATION MEASURES ..... 21
  - 4.1 Bespoke Mitigation Measures ..... 21
  - 4.2 Excavating stockpiles covered with geojute ..... 21
- 5 MONITORING SCHEDULE ..... 23
  - 5.1 Soil Handling and Storage Monitoring Protocol ..... 23
- 6 REFERENCES ..... 25

**List of Tables**

- Table 1: Testing for moisture state ..... 8
- Table 2: Consistency testing ..... 8
- Table.3: Record keeping and monitoring during the construction phase..... 23

**Note**

The purpose of this Plan is to set out how the mitigation commitments described within the Environmental Statement will be delivered during construction. The exact roles and responsibilities described in the Plan are subject to the appointment of a Contractor and may change. The Plan will be finalised by the Contractor prior to the commencement of construction taking into account a detailed scheme design and more precise information about construction methods and phasing.

## Glossary & Abbreviations

Glossary of Terms	
Term	Meaning
Field Capacity	The condition in which the soil is saturated with water and any water from rainfall will infiltrate quickly under the force of gravity or create waterlogging.
Soil Ped	Soil peds are natural, relatively permanent aggregates of soil particles, separated from each other by voids or natural surfaces of weakness; and which persist through cycles of wetting and drying.
Plastic	A plastic material can be moulded into a shape and the material will retain that shape. When a soil is in a plastic state it is considered to be too wet to be handled.
Lower Plastic Limit	The lower plastic limit is defined as the moisture content at which soil begins to behave as a plastic material. If the moisture content is below the lower plastic limit, it is considered to behave as a solid, or a non-plastic material.
Tilth	Soil tilth is its physical condition, especially in relation to its suitability for planting or growing a crop. Soil with good tilth has large pore spaces for air infiltration and water movement. Roots only grow where the soil tilth allows for adequate levels of soil oxygen. Such soil also holds a reasonable supply of water and nutrients.
UK Onshore Scheme	The Scheme comprising the proposed converter station, access road and AC and DC underground cables, including all land temporarily required during construction.

List of Abbreviations	
Abbreviation	Meaning
AC	Alternating Current
ALC	Agricultural Land Classification
ALO	Agricultural Liaison Officer
BBC	Boston Borough Council
CDM	Construction (Design and Management) Regulations 2015
CEMP	Construction Environmental Management Plan
DC	Direct Current
DEFRA	Department for Environment, Food and Rural Affairs
ELDC	East Lindsey District Council
LDC	Land Drainage Consultant

List of Abbreviations	
Abbreviation	Meaning
LGP	Low Ground Pressure
LoD	Limits of Deviation
LPA	Local Planning Authority
MAFF	Ministry of Agriculture, Fisheries and Food (now DEFRA)
NGVL	National Grid Viking Link
NKDC	North Kesteven District Council
RAMS	Risk Assessment & Method Statements
SHDC	South Holland District Council
SHSP	Soil Handling and Storage Protocol
TCC	Temporary Construction Compound
TSA	Technical Specialist Advisor
WA	Wardell Armstrong LLP

# 1 Introduction

## 1.1 Introduction

- 1.1.1 The Soil Handling and Storage Protocol (SHSP) sets out principles and procedures for good practice (embedded mitigation measures) and bespoke mitigation measures in soil handling, storage and reinstatement to be used for the UK Onshore Scheme. This outline plan describes the principals that the appointed Contractor will follow to minimise adverse effects on the nature and quality of the soil.
- 1.1.2 To secure effective delivery of the SHSP, the Contractor must implement it through site-specific soil management method statements (or similar) for the construction phase. The works must also be monitored to audit compliance with the SHSP (and location-specific construction method statements); and to allow ongoing advice on soil handling to be provided. The SHSP is based upon guidance such as the Department for Environment, Food and Rural Affairs (Defra's) Construction Code of Practice for the Sustainable Use of Soils on Construction Sites (Ref: 1-1); the Ministry of Agriculture, Fisheries and Food's (MAFF's) Good Practice Guide for Handling Soils (Ref: 1-2), and the consultant's experience.
- 1.1.3 The SHSP assumes that all mitigation measures pertaining to protected species and other environmental issues are in place, such that the soil stripping, storage and reinstatement operations can proceed.
- 1.1.4 The SHSP is considered to be a 'live document' to be updated as further information becomes available. The SHSP will be revised prior to commencement of construction operations to consider the site-specific soils data collated by the appointed specialist agricultural land drainage consultant as part of the agricultural drainage design works.

## 1.2 Roles and Responsibilities

- 1.2.1 The effective implementation of the SHSP requires that roles and responsibilities are clearly defined and understood. Specific job titles, roles and responsibilities will be defined by the Contractor in the location specific construction management plans; however, the roles and responsibilities are expected to be similar to those described below, as described in the Construction Environmental Management Plan (CEMP) (REF 1-8).
- 1.2.2 The appointed Contractor will be responsible for the preparation and subsequent implementation of site-specific soil management method statements and RAMS (or similar) for the construction phase.

### Construction Manager

1.2.3 Responsible to the Project Manager for:

- Determining and sourcing the plant and equipment to be used;
- Ensuring that working areas, services and stockpiles are clearly marked;
- Ensuring that records are maintained; and
- Ensuring that staff receive appropriate training regarding soil handling issues such as stop conditions and soil testing requirements.

### Site Foreman

1.2.4 Responsible to the Construction Manager for:

- Implementing the site-specific construction soil management method statements to manage soil handling and storage on site to ensure the sustainable use of the soil resource;
- Ensuring daily records of weather conditions, stoppages and soil plasticity (moisture) testing are made and kept;
- Ensuring that works are carried out safely, under correct conditions and in compliance with wider environmental requirements; and
- Ensuring that the protection of services is maintained during the soil handling works.

### Safety Advisor

1.2.5 The safety adviser is responsible to the Project Manager for:

- Ensuring the plant operators have the relevant training and certification.

### Agricultural Liaison Officer (ALO)

1.2.6 The Agricultural Liaison Officer (ALO), or similar, will ensure that the specifications of the SHSP and site-specific construction method statements/soil management plans are implemented. It is envisaged that the ALO will have sufficient soil science experience or that he/she will work in cooperation with a Technical Specialist Advisor (TSA) with soil science capability. The main duties of the ALO will comprise, but will not be limited to:

- liaison between the Contractor, landowners and National Grid Viking Link (NGVL);
- assessment of the soil condition during and after the works using tactile and visual methods;
- assessing compliance of the work on site with the SHSP;
- signing off the quality of restoration to allow for the commencement of the aftercare;
- ensuring the adequacy of the detailed aftercare programme and its annual updates (if required);



- soil sampling and production of annual aftercare reports; and
- signing off completion of the aftercare.

### Technical Specialist Advisor

1.2.7 The main duties of the TSA will comprise, but will not be limited to:

- providing advice with respect to construction activities and their interface with respective technical areas of expertise;
- undertaking any necessary pre-construction surveys and supervising the implementation of specific mitigation measures, where required;
- undertaking any required monitoring related to their specialism;
- providing reports and maintaining contact with relevant stakeholders, as required; and
- providing specific advice with respect to any issues that arise.

## **1.3 Limitations of use of the SHSP**

1.3.1 The SHSP should be read in conjunction with Project Documents, including the CEMP (REF 1-8) and other plans and protocols referred to therein. The SHSP does not provide safe working guidance and should be read in conjunction with the relevant detailed construction method statements and risk assessments prepared by the appointed Contractor. Attention is drawn to the responsibilities arising from the Construction (Design and Management) Regulations (CDM) 2015 (Ref: 1-3).

1.3.2 Persons involved in the handling of soils and overburden or similar, and in the construction or removal of mounds or tips, must comply with the Health and Safety at Work Etc. Act 1974 and its relevant statutory provisions, in particular, those aspects which relate to the construction and removal of tips, mounds and similar structures (Ref: 1-4). This requirement takes precedence over any suggested practice presented in this document. The user of the SHSP is solely responsible for all liabilities that might arise. No liabilities are accepted for any losses of any kind arising from the use of this SHSP.

## **1.4 Review and updated of the SHSP**

1.4.1 As discussed above, the SHSP is considered to be a 'live document' as changes are likely to be required to the SHSP throughout the construction phase of the UK Onshore Scheme for one or more of the following reasons:

- A new environmental sensitivity is identified as a consequence of changing environmental conditions, or following more detailed or additional survey work;
- Changes are introduced into the detailed design of the UK Onshore Scheme which are within agreed limits of deviation (LoD) in the development consent; or
- Changes are introduced to construction methodology or programming.

- 1.4.2 The SHSP will be reviewed prior to commencement of construction to consider the site-specific soils data.
- 1.4.3 The changes to SHSP should be implemented via an agreed procedures and changes approved by the ALO.

## 1.5 Soil Resource

- 1.5.1 The erodibility of a soil (susceptibility to damage and loss) influences the level of mitigation required to protect it and the measures to be put in place through the SHSP and site-specific construction method statements.

### Soils with low risk of erosion.

- 1.5.2 Good practice (embedded mitigation) measures following those recommended in Defra's Construction Code of Practice for the Sustainable Use of Soils on Construction Sites (Ref: 1-1); MAFF's Good Practice Guide for Handling Soils (Ref: 1-2), will provide appropriate protection to these soils as they are generally more resistant to damage and loss.

### Soils with moderate risk of erosion.

- 1.5.3 Good practice (embedded mitigation) measures will mostly provide appropriate protection to these soils, however damage is likely to occur if worked in less than ideal conditions, for example when the soils are wet. Therefore, on a location by location basis, depending upon factors such as physical soil properties and local topography, bespoke mitigation measures may be required. The soils should be given appropriate consideration because of their importance for agricultural production.

### Soils with high risk of erosion

- 1.5.4 Development on those soils should be avoided if possible, however where this is not possible, they require special consideration and careful planning of construction methods, i.e. bespoke mitigation measures, in order to preserve their structure and function.

## 2 Good Practice Mitigation

### 2.1 General principles of soil handling

2.1.1 The main threats to soil resources at construction sites are trafficking of vehicles/plant and incorrect handling, which can cause damage to soil structure through compaction and smearing (both effects are sometimes referred to as deformation). These effects compromise the ability of the soil to perform its functions, such as providing adequate amounts of water, air and nutrients to plant roots. The risk of compaction and smearing increases with soil wetness. To minimise the risk of damage to soil structure, the following main rules must be observed during all soil handling tasks:

- No trafficking/driving of vehicles/plant or materials storage to occur outside designated areas.
- No trafficking/driving of vehicles/plant on reinstated soil (topsoil or subsoil).
- Only direct movement of soil from donor to receptor areas (no triple handling and/or *ad hoc* storage).
- No soil handling to be carried out when the soil moisture content is above the lower plastic limit (the soil is plastic, see paragraphs 2.2.12 to 2.2.16 and Tables 1 and 2).
- Soils should only be moved under the driest practicable conditions and this must take account of prevailing weather conditions. (see rainfall “stop” criteria in paragraph 2.2.1).
- No mixing of topsoil with subsoil, or of soil with other materials.
- Soil only to be stored in designated soil storage areas.
- Plant and machinery only work when ground or soil surface conditions enable their maximum operating efficiency.
- All plant and machinery must always be maintained in a safe and efficient working condition.
- Daily records of operations undertaken, and site and soil conditions should be maintained (see section 5 for the summary of monitoring and record keeping schedule).

2.1.2 Low ground pressure (LGP models) and tracked vehicles should be used where possible. This will greatly minimise the extent and/or intensity of the soil loosening required after restoration. Consequently, it will reduce the costs and potential delays due to the need for additional soil cultivation.

2.1.3 The location-specific methods statements (or similar) must be defined based on the results of detailed site-specific soil survey. Site surveys have been conducted by LDC in areas of temporary development, e.g. the proposed Direct Current (DC) cable route; and by Wardell Armstrong (WA) in areas of permanent development; e.g. the proposed converter station and access road. Additionally, it is assumed that, unless under the terms of contract the Contractor is

to commission their own surveys, these data will be made available to the Contractor. It is noted that additional survey may be required should there be gaps or omissions in the survey data due to access issues or route changes. The survey results should be used to specify in detail:

- The 'before' statement of physical characteristic of the soil to be disturbed;
- where bespoke mitigation measures are required, and what these bespoke measure entail;
- the depth and properties of topsoil; and
- the depth of subsoil and presence of any distinct soil horizons.

## 2.2 Stop conditions

### Adverse weather

2.2.1 In certain weather conditions, the handling of topsoil and subsoil must be effectively managed to prevent damage. Topsoil and subsoil handling must cease applying the following criteria:

- in drizzle and/or intermittent light rain, handling can continue for up to four hours unless the soils are already in a plastic state (see paragraph 2.2.12);
- if there is heavy rain (e.g. heavy showers, slow moving depressions), handling must stop immediately;
- if there is sustained heavy rainfall of more than 10 mm in 24 hours, soil handling must be suspended and not restarted until the ground has had at least a full day to dry, or an agreed soil moisture limit can be met; and
- soil shall not be handled or trafficked over/driven on immediately after a heavy rainfall (or snow/hail) in a waterlogged condition, or when there are standing pools of water on the soil surface.

2.2.2 If the works are interrupted by a rainfall event, soil stripping should be suspended; and where the soil profile has already been disturbed, the works should be completed to the base level in that location.

2.2.3 Before recommencing work, soil moisture content must be tested, as described in 2.2.12 to 2.2.16 and Tables 1 and 2, and only recommence if soil moisture is below the lower plastic limit. The weather forecast must also be checked and works only recommenced if there is no rain forecast for at least a day, regardless of soil moisture condition.

2.2.4 Additionally, soil should not be handled or trafficked over/driven on when the ground is frozen or covered by snow.

2.2.5 The above criteria should be clearly understood by all personnel.

### Soil conditions

2.2.6 Irrespective of the weather, soils should not be handled when in a plastic state (when moisture content exceeds their lower plastic limit); and as a general rule should be dry when handled.

- Paragraphs 2.2.12 to 2.2.16 and Tables 1 and 2, set out the methodology for determining whether soils are in a state where they can be handled.
- 2.2.7 A project-wide seasonal constraint to the construction programme is not recommended as this may not be achievable in practice. The soil types identified within the UK Onshore Scheme (Chapter 9; ES-2-B.05 and Chapter 22; ES-2-C.04) combined with the moderately high excess winter rainfall in the Region, mean that soil handling should ideally be restricted to the drier periods of the year.
- 2.2.8 However, due to the scale of the UK Onshore Scheme, it is understood that soil handling when the soils are in a plastic state may be necessary.
- 2.2.9 If the soil is excavated and placed in stockpiles when wet (above the plastic limit), they are easily compacted by the machinery handling them, or by the weight of the soil above it in the stockpile. As well as this damage to soil structure, when soils within a stockpile are compacted, the core of the stockpile remains anaerobic throughout the storage period. This damage results in the soil being very difficult to handle and re-spread at the time of reinstatement (i.e. it will not be in a friable state and will not break down into a suitable tilth). In this case, in order to achieve the required standard of restoration, a period of drying and appropriate additional cultivation is required (to repair soil structure and re-aerate the soil) to ensure the soil is acceptable for planting. The costs of these unplanned operations, and consequent delays to the programme of works, could be substantially, if not several times, greater than the costs of ensuring that the soil stripping and stockpiling operations are carried out in optimum conditions and making allowances for delays due to bad weather.
- 2.2.10 For arable land, the period where the soil conditions will generally be the driest typically occur in the summer following the spring crop harvest, when the plant evapotranspiration will have dried the soil.
- 2.2.11 Once the placement of soils into each stockpile has been completed, rainfall and soil moisture conditions are of lesser importance, providing they do not lead to significant environmental impacts, such as erosion and discharges of sediment laden water from the stockpiles to drainage ditches and other watercourses.

#### Field testing of soil conditions

- 2.2.12 The following two stage methodology, comprising a moisture state test and a consistency test, has been recognised by Natural England as an acceptable and valid approach; as it is considered to be less open to interpretation and easier to conduct than use of consistency testing (Table 2) alone.
- 2.2.13 At least five points per area to be worked on a given day should be sampled (a minimum of 1 point per 50 m of the length of the working area, or 2 samples per ha). The sample should be a composite of at least five subsamples from around each sample point. Samples of both topsoil and subsoil should be taken and sampled separately.

Soil moisture state

2.2.14 The samples should first be tested for soil moisture state.

Table 1: Testing for moisture state	
Test	Handling allowed?
If soil sample is wet, films of water are visible on the surfaces of grains and aggregates; or If soil sample readily deforms into a cohesive 'ball' when squeezed.	Soils should not be handled.
Soil peds break up/crumble readily when squeezed in the hand. Sample does not form a cohesive ball.	Soils can be handled.
If the sample is moist, there is a slight dampness when squeezed between the fingers, but it does not significantly change colour (darken) on further wetting.	No handling by dozers, but may be handled by excavators <b>if</b> the consistency test is passed.
Sample is dry and brittle. Sample looks dry and changes colour (darkens) on wetting.	Soils can be handled <b>if</b> the consistency test is passed.

Consistency

2.2.15 Where required as per Table 1, samples should be further tested for consistency.

Table 2: Consistency testing	
<b>STEP A</b> Attempt to roll sample into a ball by hand	
It is impossible because the soil is too hard (dry).	Soils can be handled.
It is impossible because the soil is too loose (dry).	Soils can be handled.
It is impossible because the soil is too loose (wet).	Soils should not be handled.
It is possible to roll the sample into a ball by hand.	See Step B
<b>STEP B</b> Attempt to roll the ball into a thread of 3 mm diameter on a flat non-adhesive surface using light pressure from the flat of a hand	
It is impossible as the soil crumbles or disintegrates.	Soils can be handled.
It is possible to roll a 3 mm diameter thread.	Soils should not be handled.

- 2.2.16 The final decision on whether soil handling can commence will be made based upon at least 80% of samples passing the particular test. The above criteria should be clearly understood by all personnel.

## 2.3 Preparation

- 2.3.1 Mark and signpost the undisturbed areas where no construction activities or vehicle trafficking over/driving on is to take place per detailed works plans and construction method statements (to be prepared post-consent by the Contractor). Any trees, hedgerows or valuable habitats which are to be retained should be marked out with barrier tape; and subsequently protected and managed.
- 2.3.2 As per the requirements of detailed works plans and construction method statements (to be prepared post-consent by the Contractor), any underground services crossing the area of soil stripping area are to be surveyed and their depth and position clearly marked to ensure they are not impacted by the stripping works. After stripping, to ensure the integrity of the service infrastructure is maintained, the service location may require fencing off; or if the area over the service is to be trafficked additional protection or mitigation may be required.
- 2.3.3 Mark soil storage areas for different types of topsoil, subsoil and mineral substrate. In some locations, the excavated soil profile may contain more than one distinct subsoil horizon (layer). Where this occurs, due to the different properties of the different horizons, they must be excavated and stored separately. Locations requiring the storage of more than one subsoil horizon should be identified through review of the soil survey records, see paragraph 2.1.3, and specified in the location-specific construction method statements.
- 2.3.4 At designated crossings (specified in the location-specific construction method statements) a 2 m width of topsoil will be left unstripped at either side of the ditch/watercourse to act as a filter for water run-off.
- 2.3.5 To reduce the likelihood of anaerobic conditions developing within the topsoil stockpile prior to the soil strip commencing the topsoil surface should either be bare, under stubble, or have only short surface vegetation. To achieve short surface vegetation (for example in areas of permanent pasture or under a hay crop), if not already done so prior to the land being handed over to the Project, the area should be mown or strimmed. Cuttings should be disposed of off-site to a suitably licenced facility with reuse and recycling favoured over disposal (e.g. recycling via a local composting facility). Cuttings must **not** be added to or mixed with the stripped soil, as the presence of excessive amounts of plant material in the stockpile will be detrimental to its quality due to its putrefaction (rotting) in anaerobic conditions. Alternatively, the vegetation may be killed off by application of a suitable, Environment Agency approved, non-residual herbicide applied not less than two weeks prior to commencement of soil stripping operations at the location. Herbicide may only be used with the consent of the landowner and subject to the conditions/restrictions within the contract.

- 2.3.6 The site staff must be competent to perform the tasks as they have the potential to cause an environmental impact. The training and awareness is to be ensured according to the procedures and tools described in the Construction Environmental Management Plan (CEMP). Carry out toolbox talks with all personnel involved in the groundworks communicating the principles of good practice in soil management and its goals.

## 2.4 Soil stripping

- 2.4.1 Topsoil can be stored on either topsoil (of the same type) or on subsoil. Subsoil can ONLY be stored on subsoil and therefore the topsoil must be stripped from subsoil storage areas in advance of subsoil stripping.
- 2.4.2 The stripping method should follow one of the suggested methods as described in the MAFF's Good Practice Guide to Handling Soils (Ref: 1-2). When preparing the trenches for installing the proposed Direct Current (DC) and Alternating Current (AC) cables and during the preparation of the working areas, the excavated sub soil will be stored on the opposite margin of the working area to the top soil,
- 2.4.3 A number of areas of known archaeological significance or high archaeological potential have been identified and will be subject to 'Strip, Map and Sample' archaeological investigation prior to the commencement of main construction activities. In these areas, the soils will be stripped mechanically (under strict archaeological supervision) to a depth where archaeological deposits are exposed. The soil strip will be subject to the mitigation measures set out in this document with respect to the management and protection of soil resources; however, a **toothless bucket** should be employed to prevent damage to the underlying archaeology. It is expected that (in most locations) the excavated soil will be stored on the margin of the working area and that the use of dumper trucks will not be required.
- 2.4.4 Where soils are to be stored away from the excavation area, two excavators and one transport vehicle will be required for soil stripping operations. One excavator will be required to undertake the soil stripping and the other to form the soil stockpiles. The excavator undertaking the soil stripping should be fitted with a toothed bucket, except in the areas of known archaeological significance or high archaeological potential (see above), where a toothless bucket should be employed to prevent damage to the underlying archaeology. The method, if correctly carried out, should avoid severe compaction as soil trafficking is minimised. The concept of this method is shown in Plate 1 and Plate 2. It is not foreseen on this project that it will be necessary to store topsoil or subsoil away from the immediate area where it has been excavated.
- 2.4.5 The size of the earthmoving plant to be used should be tailored to the size of the area to be stripped and the space available within the working area. The use of a long reach excavator, which will minimise the need for movement across the soil surface, and the use of tracked vehicles or vehicles with a low ground bearing pressure is recommended to further reduce soil compaction.



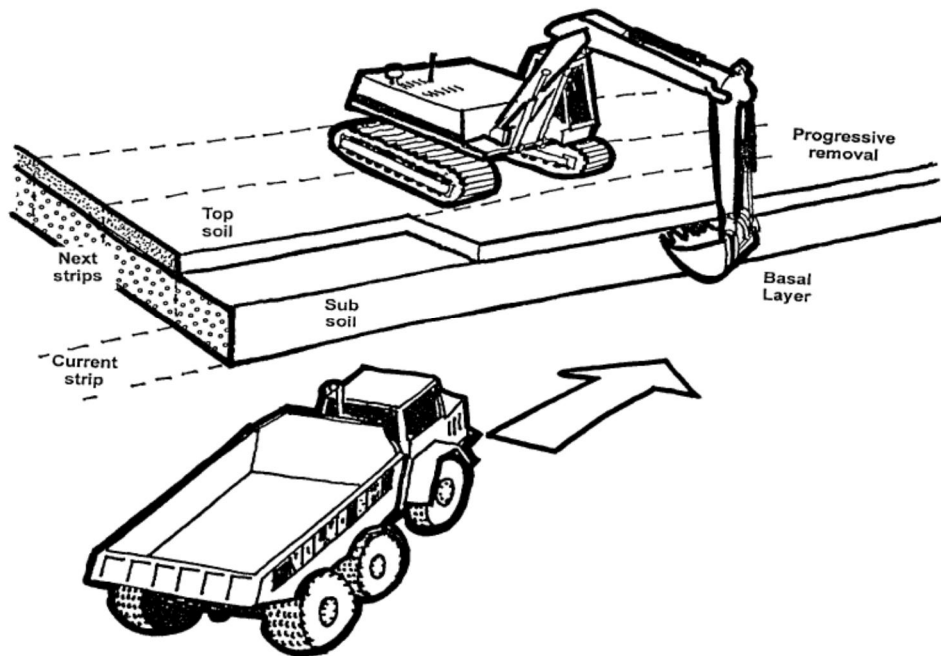

Plate 1: Stripping with excavators and dump trucks: removal of topsoil from a strip.  
 Reproduced from MAFF, 2000 (Ref: 1-2)

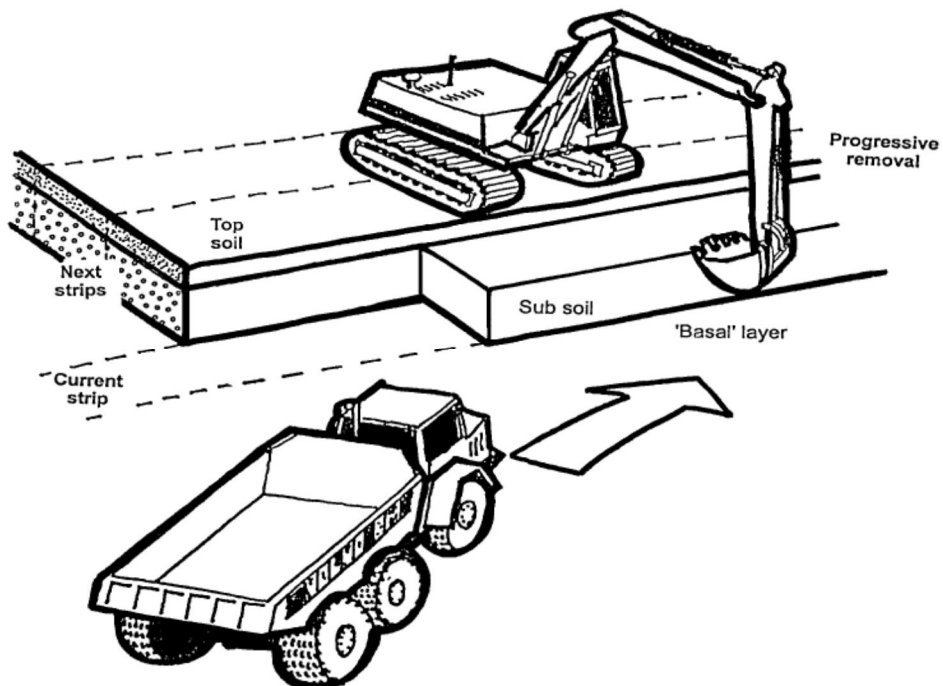

Plate 2: Stripping with excavators and dump trucks: removal of subsoil from a strip.  
 Reproduced from MAFF, 2000 (Ref: 1-2)

- 2.4.6 Prior to commencement of soil stripping, the width of each strip must be determined. Strip width is determined by the length of the excavator boom less the stand-off to operate; typically, 3 to 4 m. The strip width should make full use of the reach of the excavator. This will maximise the time the excavator can remain at a fixed location, before moving further along the strip; minimising the number of locations subject to the weight of standing plant.
- 2.4.7 The depth of the topsoil strip is to be determined on a 'location by location' basis using the soil survey data as described in paragraph 2.1.3. During the strip, the excavator should stand on the surface of the topsoil, digging the topsoil to the required depth and forming the stockpile or loading it into the transport vehicle (dump truck). Following topsoil removal, the subsoil can be excavated (if required). Topsoil should be recovered to the full width of the strip without contamination with the subsoil. The boundary between the topsoil and subsoil is usually very clearly visible through a change in colour (the topsoil being much darker due to greater organic matter content). However, this may not always be the case, as often the topsoil gradually transitions into subsoil, and their colours are similar. Therefore, the **depth of the topsoil to be stripped must be determined by measuring the depth from the surface** (excluding any vegetation) using the soil survey data as described above.
- 2.4.8 The key points to minimise soil compaction and maximise its readiness for reuse are:
- The operations of the vehicles (excavators and dumper trucks, if relevant) on the topsoil should be minimised.
  - Plant and machinery are to only work when ground conditions enable their maximum efficiency.
  - Soils should only be handled when dry (i.e. when tests set out in Tables 1 and 2 are passed).
  - Stop conditions as set out in section 2.2 must be observed.
  - Protect the subsoil from ponding of water by diverting water inflow away from it.
  - **Do not** work when there is standing water on the topsoil or subsoil surface.

## 2.5 Creation of soil stockpiles

- 2.5.1 Correct storage/stockpiling will maintain soil quality and minimise damage to soil structure and soil biota. This ensures that the soil will readily recover once re-spread, promoting timely and effective restoration. Stockpiled soil must not be vulnerable to compaction or erosion; must not cause pollution to surrounding watercourses; and must not increase flood risk to the surrounding area.
- 2.5.2 Potential soil erosion and water pollution can be minimised through a number of good practice measures, including, but not limited to; the avoidance of trafficking over/driving on the soil stockpiles, the seeding of stockpiles; and the use of intermittent spaces in the stockpiles.
- 2.5.3 Soil should not be stacked closer than 5 m from a watercourse or ditch. Gaps shall be left where necessary to allow for surface water drainage and avoid the catchment (ponding) of water behind stockpiles.

- 2.5.4 Ecologically important soils, for example woodland or hedgerow soils, must be stripped and stored separately to ensure the seedbank is retained and not mixed with neighbouring agricultural soils. These stockpiles must be appropriately marked out and clearly signed to ensure that they are easily identifiable at restoration, as specified in the location-specific construction method statements.
- 2.5.5 Generally, topsoil stockpiles should not exceed 3 m in height and subsoil stockpiles should not exceed 5 m in height. However, if the soil to be stockpiled is dry (below the plastic limit) formation of higher stockpiles may be permissible, if required, as the soil is likely to remain dry in the core of the stockpile for the entire storage period. However, the appropriateness of higher stockpiles will need to be established on a location by location basis.
- 2.5.6 Stockpiles are to be formed by 'loose-tipping' followed by 'shaping' to form a level surface on top of the pile and uniform gradients down the sides. During 'forming', the top and sides should be smoothed so that they can shed water, ensuring that the entry of the water to the stockpile is limited and that the stored soil remains dry; and helping prevent erosion and ponding. This is achieved by dragging the bottom of the excavator bucket along the stockpile surface.
- 2.5.7 The natural angle of repose of a soil, and hence the maximum gradient (slope) of the stockpile sides, depends upon its texture and moisture content. The maximum achievable slope angle is 40° however, shallower angles are often more appropriate. As the stockpiles for the UK Onshore Scheme are to be seeded and maintained, a maximum slope of 25° (1 in 2) is considered appropriate, however this will be defined in location-specific construction method statements.
- 2.5.8 The topsoil and subsoil stockpiles along cable trenches are to be formed using one back-acting/360° excavator as they will be too close to the excavation to require transport in a separate vehicle.

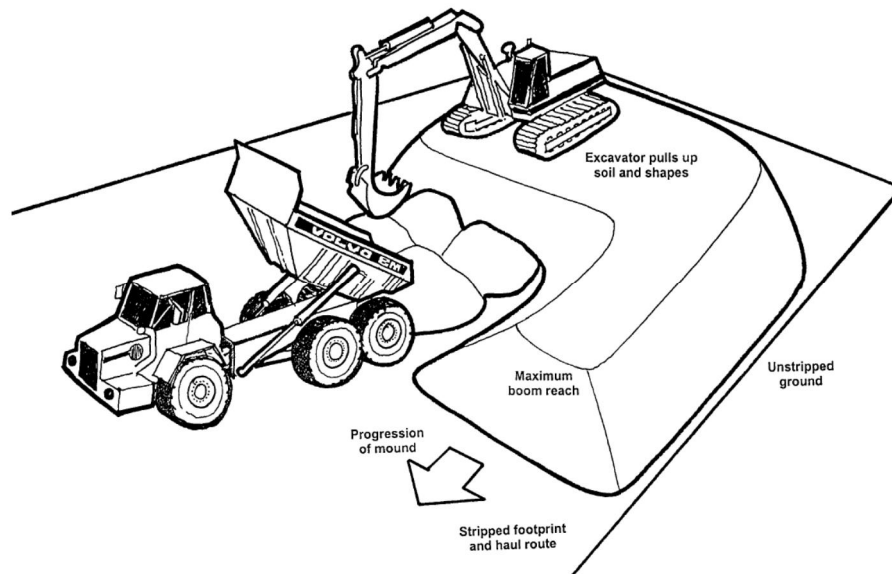

**Plate 3: Soil storage mound construction with excavators and dump trucks. Reproduced from MAFF, 2000 (Ref: 1-2)**

- 2.5.9 If transport is required, follow the method described in the MAFF Guide, Sheet 2: Building Soil Storage Mounds with Excavators and Dump Trucks illustrated in Plate 3 (Ref: 1-2). A dump truck should transfer soil material between the stripping and storage areas. The dump truck should enter the storage area, reverse and back-tip the soil load starting at the furthest end of the stockpile (see Plate 3). Repeat the process of tipping the soil against the forming stockpile and without the wheels traversing onto previously tipped material. For this operation, a second back-acting/360° excavator will be required with the boom reach allowing it to form a stock pile of up to 4 m while standing on it.
- 2.5.10 Use of a front-loading machine to form the stockpile is possible if this is a Contractor's preference. If this alternative is chosen; the tipped soil must not be travelled or pushed with a bulldozer blade. It must be lifted by the front-loading machine and tipped into place to form a desired stockpile height. The top and side surfaces of the stockpile must be formed so as to shed the rainwater.

## 2.6 Access along cable trenches

- 2.6.1 The subsoil will be used as the surface of temporary haul roads within the proposed cable working area. Whilst preliminary data from the LDC soil surveys have identified the subsoils along the cable route to have a moderate to high bearing capacity, 'bog mats' or stone tracks may be required where the subsoil bearing capacity is not sufficient to support the construction vehicles.

## 2.7 Stockpile Maintenance

- 2.7.1 It is expected that the soil will be stored for a period of more than six months. Therefore, the stockpiles should to be seeded with appropriate low maintenance grass/clover mixture (for example EG22c Emorsgate Seed, or similar: to be agreed with landowner and subject to the conditions/restrictions within the contract; to protect the soil against erosion, minimise soil nutrient loss, and maintain soil biological activity. Appropriate seeding will also help prevent colonisation of the stockpile by nuisance weeds that could spread seed onto adjacent land.
- 2.7.2 In the period where vegetative cover on the stockpiles is establishing, where required during dry weather, the stockpiles will be sprayed with water to prevent wind erosion (generation of dust) and to ensure that the seeds establish.
- 2.7.3 The stockpile vegetation cover is to be managed (by spraying, mowing or stripping as appropriate and as defined in location-specific construction method statements, or similar), to prevent the spread of seeds from the stockpile onto adjacent land.
- 2.7.4 The condition of the stockpiles is to be regularly monitored. If rainwater gathers on the stockpile surface or in areas directly adjacent to them, drainage pathways to soakaway area away from the stockpile should be provided.

## 2.8 Stockpile Records

- 2.8.1 The locations and footprints of each stockpile should be accurately recorded on a plan of appropriate scale. Marker post should be provided in locations which have been surveyed and recorded.
- 2.8.2 The approximate volume of each stockpile should be recorded, along with details of the type of soil stored.

## 2.9 Drainage

- 2.9.1 Prior to soil stripping, where required, pre-construction drainage will be installed per specification provided by a specialist drainage contractor. This drainage is designed to prevent water entering the working area.
- 2.9.2 Gaps shall be left between soil stockpiles where necessary to allow for surface water drainage and avoid the catchment (ponding) of water behind stockpiles. In certain areas (as defined in location-specific construction method statements or similar) 'grips' may be dug across the working area at predetermined locations to prevent erosion and prevent ponding against stockpiles. Appropriate measures such as stones silt traps and silt fencing will be employed as required.

## 2.10 Restoration

- 2.10.1 Most of the land disturbed as a consequence of the UK Onshore Scheme will be restored to agricultural use; however, it is noted that some areas will be restored to a different land use (for

example stripped. In most locations, direct excavation of the soil from the stockpiles using a long-reach back-acting/360° excavator will be possible. Where larger stockpiles are created and there is a necessity for soils to be transported to the reinstatement area via dump truck, for example at the proposed converter station site or at the Temporary Construction Compounds (TCC), stockpile excavation is to follow the methodology described in MAFF Guide, Sheet 3: Excavation of Soil Storage Mounds with Excavators and Dump Trucks (Ref: 1-2). In this method, the dump trucks enter the storage area travelling on the base layer (where topsoil and subsoil stripped) and on the subsoil (where only topsoil stripped). If back-acting/360° excavator is used it must stand on top of the stockpile to load the dump truck (see Plate 4). The stockpile is dug to the base (the original subsoil) before moving progressively back along its axis. the landscaping zone within the proposed converter station site). Also, some areas will be returned to wildlife habitat including hedgerows.

- 2.10.2 The main objective for the restoration of agricultural land is to reinstate the land to its original (pre-development) Agricultural Land Classification (ALC) grade. This is primarily achieved by ensuring that the full soil profile is restored in the correct sequence of horizons, and in a state where good soil profile drainage and plant root development are achieved; and by ensuring that the reinstatement works cause minimum damage to soil structure.
- 2.10.3 Therefore, soil restoration has been designed to achieve soil profiles as close to the original (pre-construction) as possible, which is a pre-requisite for the maintenance of the original agricultural land quality/other prior land use.

## **2.11 General methods to be used during restoration**

- 2.11.1 Soil reinstatement shall be subject to the same constraints of weather and soil moisture conditions as soil stripping (see section 2.1 above). All methods must adhere to the general principles set out below.

### Excavation of soil stockpiles

- 2.11.2 The size of the earthmoving plant to be used should be tailored to the size of the area to be

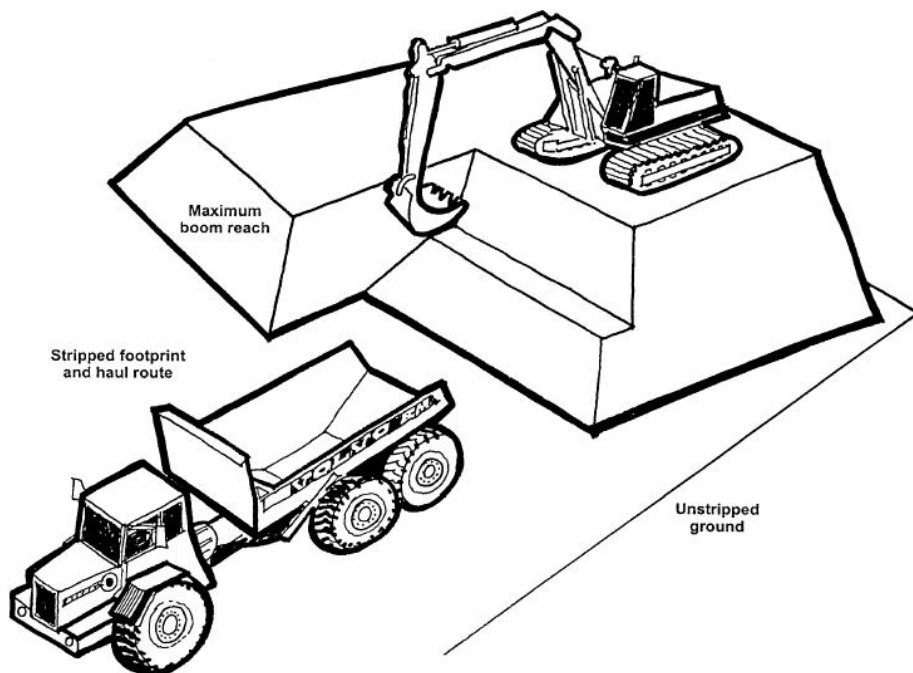

**Plate 4: Excavation of soil storage mound with excavators and dump trucks. Reproduced from MAFF, 2000 (Ref: 1-2)**

- 2.11.3 Front loading machines may be used, in which case they will not need to enter the top of the stockpile.
- 2.11.4 Any exposed edges/surfaces should be shaped at the onset of rain and at the end of each day (see paragraph 2.5.6).

Placement of excavated materials

- 2.11.5 Where restoration involves the replacement of excavated materials other than soils (i.e. material (overburden) from a depth greater than the base of the subsoil); the overburden must be replaced first. The overburden material may be overfilled by 10 to 15 % to allow for settlement to the design profile.
- 2.11.6 Following the placement of overburden to form the base layer, where required, the surface should be graded to the required landform and any debris removed before soils are reinstated. Similarly, where required, the surface of the overburden should be loosened to an appropriate depth of not greater than 1.2.m.

Soil reinstatement

- 2.11.7 Soil reinstatement is the reverse of soil stripping with topsoil being replaced over subsoil. The specifications for reinstated soil profiles are to be determined on a location by location basis using the soil survey data as described in paragraph 2.1.3; and set out in location-specific

- construction method statements. Care must be taken to ensure that soil horizons are replaced to the correct thickness (with an allowance of up to 20% to allow for settlement).
- 2.11.8 In most locations, direct excavation and restoration of the soil from the stockpiles using a long-reach back-acting/360° excavator will be possible. In this method, the subsoil will be replaced first, with the excavator travelling on the subsoil and gradually taking the topsoil from the stockpile, and depositing it on the subsoil. The deposition is to be carried out by loose tipping and a toothed digger bucket is to be used.
- 2.11.9 Soil replacement is generally to follow the methodology set out in MAFF Guide, Sheet 4: Soil Replacement with Excavators and Dump Trucks (Ref: 1-2). In this method, the soil is replaced in strips above the base layer to recreate the original soil profile. The topsoil is replaced on the previously decompacted subsoil. The replacement is carried out in strips in a similar manner to the stripping operations. First, the initial strip width and axis is to be demarcated. The width of the strip is determined by excavator boom length less the stand-off to operate; typically, 5 to 8 m. A wide bladed bucket should be used to spread the soil (use of a toothed bucket must be avoided in this case).
- 2.11.10 The dump truck should reverse to the edge of the current strip and tip the lowest layer, without the wheels riding onto the strip. The dump truck **must not** drive away until all the soil is deposited within the strip without spillage over the basal layer. To achieve this, assistance from the excavator to 'dig away' some of the tipped soil may be required. The tipped soil should be spread to the full thickness required, by the excavator utilising the digging, pushing and pulling action of the bucket. Each load must be spread before another is tipped. Repeat the process along the strip until it is completely covered with the required depth of the soil layer. Should the spread soil comprise of large blocks (>0.3 m), they should be broken down by 'slicing' them with the excavator bucket.

### Soil decompaction

- 2.11.11 Due to the use of subsoil as the working surface during the cable placement, subsoil decompaction will be required prior to the placement of the topsoil, the method using a low ground pressure bulldozer either fitted or towed with winged subsoiler tines is recommended. For the decompaction to be effective, the moisture content of the soil must be below the lower plastic limit, so that the soil is dry enough to shatter and for fissures to be created. As the soil in the trench is to be deposited through loose tipping (see earlier section), no ripping of the trench area will be required.

## **2.12 Achieving the restoration standard**

- 2.12.1 The quality of the soil reinstatement will need to be verified by the ALO as described in paragraph 2.12.4.



- 2.12.2 Post-restoration surveys will be required across all land reinstated to agriculture, to determine whether target soil profile specifications have been met. The aftercare will commence after soil characteristics achieve the restoration standard.
- 2.12.3 The TSA will conduct post-construction soil surveys to record the 'after' statement of physical characteristics of the restored soils.

#### STATEMENT OF PHYSICAL CHARACTERISTICS REPORT

- A report normally produced in conjunction with an agricultural land classification survey, which describes the different soil profiles in detail, allowing the restoration of the site to be judged against this benchmark.

(Defra, 2004)

- 2.12.4 The ALO will then compare it to the 'before' statement to verify that the land has been restored to the required standard. If the restored soil properties are found to differ from the 'before' characteristics to an extent that makes it impossible for the standard to be reached, the remediation will need to be carried out before the aftercare commences. This approach will ensure that any problems are identified and rectified early after construction. This will in turn minimise the period of aftercare and risk of compensation claims.

## 2.13 Aftercare

### Responsibilities and content of the aftercare

- 2.13.1 The aftercare will be the responsibility of the Contractor, it will include treatments such as: cultivation (e.g. subsoiling), installation of underdrainage, seeding, liming and fertilising, as and when required. The aftercare programme is to be agreed between the Contractor, landowner, and (if applicable) tenant farmer. It will clearly define who is responsible for which part of the programme. For example, the Contractor may be responsible for initial soil testing (to determine lime and fertiliser requirements) and installation of drainage, the tenant farmer may be responsible for carrying out the cultivation and fertilisation.

### Period of the aftercare

- 2.13.2 Due to the lack of differential settlement, a flexible period of aftercare of minimum one year is suggested, with the aftercare deemed complete when the restoration standard has been achieved. It will be the responsibility of the ALO to determine when the restoration standard has been met.

## 3 Biosecurity

### 3.1 Biosecurity

- 3.1.1 During large-scale projects, there is the potential for disease and pathogen transfer between different areas of agricultural land (i.e. a biosecurity risk). The loss of soil resource is considered as the main cause of disease and pathogen transfer, due to the transfer of soil from infected to uninfected areas.
- 3.1.2 To minimise the biosecurity risk, including the potential transfer of disease, pathogens and weeds, the use of best practice measures, such as the good practice guidelines set out in section 2, will minimise soil loss and soil movement through erosion, excess trafficking on plant wheels, or unauthorised export, for example.
- 3.1.3 In addition, to minimise biosecurity risks, appropriate cleaning and/or disinfection of machinery between holdings to mitigate against any disease outbreak or transfer of weeds between holdings. This will be particularly important for intensive pig and poultry units, cattle and any land with organic designations.

## 4 Bespoke Mitigation Measures

### 4.1 Bespoke Mitigation Measures

- 4.1.1 Additional (bespoke) mitigation measures are required for soils identified as being of high or medium risk or erosion (by water or wind); and therefore sensitive to damage and susceptible to loss.
- 4.1.2 A review of the available high-level soil data (Ref: 1-5 and Ref: 1-6) and soil erodibility data derived from Knox *et al.*, 2015 (Ref: 1-7) shows that soil resources at high risk of erosion belonging to the Cuckney association comprise 36.6% of the proposed DC cable working width (35.1% of the Zone of Influence (Zol)) in Section 2 (Well High Lane to A16 (Keal Road)). Soils of the Andover 1 and Swaffham Prior associations are of medium risk of water erosion. Andover 1 soils comprise 3.2% of the proposed DC cable working width (3.1% of the Zol) of Section 1 (southern end) (Boygrift to Well High Lane); and together Andover 1 and Swaffham Prior soils comprise 33.1% of the proposed DC cable working width (34.7% of the Zol) in Section 2 (See Chapter 9; ES-2-B.05). No erosion prone soils were identified within Sections 3 and 4 of the proposed DC cable route, within the proposed converter station site or along the proposed AC cable route.
- 4.1.3 Prior to construction the detailed soil survey data collated by the LDC for the DC cable route should be interrogated to define the extent of the erosion prone soils at the field level; allowing location-specific construction method statements (or similar) to be developed. Furthermore, the detailed LDC survey data may identify small areas (pockets) of erosion prone soils which are not identified in the high-level data; and bespoke mitigation should also be described for these areas within location-specific construction method statements.
- 4.1.4 The stockpiles for these soils should be formed and seeded as described in section 2.5. The stockpile may then be covered in geojute<sup>1</sup> (or similar geotextile covering) to stabilise it until the vegetation cover becomes effective. Depending upon specific site and soil conditions, other bespoke mitigation measures for erosion sensitive soils will be expected to include, but not necessarily be limited to: the use of specialist surface run-off control systems and wind barriers.

### 4.2 Excavating stockpiles covered with geojute

- 4.2.1 Gradually remove the geojute from the stockpiles as the excavation progresses leaving enough to cover the end of the stockpile at the end of the working day (or during rain stoppage). Remove the geojute off-site to a local green waste composting facility or other suitably licenced facility. It

---

<sup>1</sup> Example of the product and datasheets are available here: <http://greenfix.co.uk/product/geojute/>

is expected that the amount of soil left on the geojute will be minimal and will not result in significant loss of soil.

- 4.2.2 Should the geojute be sufficiently decomposed and break into small (a few centimetres wide) fragments upon the removal, it can be left on the stockpile during the excavation and left in the reinstated soil. The suitability of this option should be assessed by the ALO.

## 5 Monitoring Schedule

### 5.1 Soil Handling and Storage Monitoring Protocol

5.1.1 Table 3 summarises the need for record keeping and monitoring during the construction phase.

Table 3: Record keeping and monitoring during the construction phase			
	What to look for	Responsibility	Frequency
Soil stockpiles	Erosion rills, water ponding, loss of protective vegetation or/and geojute cover, invasive weeds.	Contractor	Once a month and after rainfall exceeding 10 mm in 24 h
Soil handling	Conformance with the SHSP, record operations undertaken, weather and soil conditions, any problems and corrective actions undertaken.	Contractor	Daily
	Conformance with the SHSP, check daily record.	ALO	Varies, but at least once a week.
Verification of the restoration standard	Has the soil profile been restored to, as much as practicable to do so, a condition when last time used for agriculture	ALO	Once, after reinstatement, re-inspected after remediation (if applicable)
Aftercare reports	Significant differences in crop performance, compaction and waterlogging between the restored and undisturbed land	TBC	Annually until unrestricted agricultural use can commence

5.1.2 Annual reports will be prepared during the aftercare period. Minimum one report will be prepared as the proposed minimum aftercare period is one year. The aftercare report will contain results of appropriate soil testing, the TSA will determine what tests are required and carry out the testing and record the soil condition. As a minimum the testing will comprise:

- Visual assessment of plant cover and ground surface.
- A series of trial pits to assess the soil structure at depth and penetration by plant roots.

- 5.1.3 Non-conformance reporting, corrective actions, and incident responses are to be undertaken by the ALO according to the procedures described in the CEMP.

## 6 References

Ref: 1-1: DEFRA (2009) Construction Code of Practice for the Sustainable Use of Soils on Construction Sites. pp64. Accessed on 30/05/2017. Available at

[https://www.gov.uk/government/uploads/system/uploads/attachment\\_data/file/69308/pb13298-code-of-practice-090910.pdf](https://www.gov.uk/government/uploads/system/uploads/attachment_data/file/69308/pb13298-code-of-practice-090910.pdf).

Ref: 1-2: MAFF (2000). Good Practice Guide for Handling Soils. Accessed on 30/05/2017. Available at

<http://webarchive.nationalarchives.gov.uk/20090306103114/http://www.defra.gov.uk/farm/environment/land-use/soilguid/index.htm>.

Ref: 1-3: Construction (Design and Management) Regulations (CDM), 2015. Accessed on 30/05/2017.

Available at <http://www.legislation.gov.uk/ukxi/2015/51/contents/made>.

Ref: 1-4: Health and Safety at Work Act, 1974. Accessed on 31/05/2017. Available at

<http://www.legislation.gov.uk/ukpga/1974/37/contents>.

Ref: 1-5: National Soil Resources Institute, Cranfield University 1:250,000 scale National Soil Map, digital dataset (Landis NATMAP dataset).

Ref: 1-6: Soil Survey of England and Wales (1984) Soils and their Use in Eastern England and accompanying 1:250,000 map Sheet 4.

Ref: 1-7: Knox *et al.* (2015). 'Research to develop the evidence base on soil erosion and water use in agriculture: Final Technical Report. pp147'.

Ref 1-8 National Grid Viking Link (August 2017) Construction Environmental Management Plan (CEMP)







## CONTACT US

---



You can find out more information by:



calling our freephone number:  
**0800 731 0561**



Sending an email to:  
**vikinglink@communityrelations.co.uk**



Writing to our freepost address at:  
**FREEPOST VIKING LINK**



Visiting our website at:  
**www.viking-link.com**

If you, or someone you know, would like information in Braille, audio, large print or another language, please call us on the freephone number above.